

# Integration Layer Device

# PF-BM1x

## BACnet Ethernet FCU Protocol Interface

### 【Description】

PF-BM1x is a built-in converter for DF series networked fan coil controller. It can convert BUS RTU to BACnet Ethernet and MODBUS/TCP communication format to achieve the purpose of system integration. Monitoring software, music switch, network motion panel, and equipment in the corridor, such as performing group management or computer start and stop operation, adjustment of temperature, air conditioning mode, switching speed, scheduled on/fire..., time program automata and other control functions, as well as real-time Master the status of on-site temperature, system operation, wind speed operation, abnormal alarm... etc. PF-BM1x has logic operation functions to meet customized requirements, such as obtaining operation authority or user use... etc. You can also use the program of external B-AAC local administrators for chain control, such as mainframe and external air-conditioning box chain Start and stop. PF-BM1x adopts international BACnet communication and can be integrated and mutually controlled with any brand of BACnet monitoring system. In addition, it also supports MODBUS/TCP communication and can be integrated with any brand of MODBUS system. It is definitely a product for you to build a monitoring system.



### 【Features】

- Follow the BACnet Advanced Application Controller (B-AAC) level communication protocol specification formulated by the American Heating, Refrigeration and Air-Conditioning Association (ASHRAE), compatible with the BACnet system.
- With Ethernet communication interface, BACnet Ethernet or BACnet /IP communication layer communication mode can be selected
- With MODBUS/TCP Server communication function, it will automatically map the internal BACnet data (AV/BV) to the preset MODBUS data address (Register/Coil) for other MODBUS/TCP Client devices to read the information.
- It has FCnet communication interface with communication indicator, which can display the transmission and reception communication status. Each communication interface can connect 32 DF devices.
- With RS-232 communication interface, the user can use the AD-Linker cable and use the hyper terminal program to set the initial value of the device or modify the parameters.
- When connecting with the monitoring system, it has the network time synchronization function, which can accept the network time correction of the central monitoring, so that the FCnet controller time is the same.
- The operating status and command parameters of the DF fan controller on the network can be converted into standard BACnet objects, and the operating parameters can be fully edited (Note: each DFC has up to 60 points (AI\*10 /AO\*10 / AV\*10 /BI\*10 /BO\*10 /BV\*10).
- With online firmware update and DDC control functions, online editing/downloading of control logic programs and real-time debugging, and support for reading and writing external device points. .
- It has the functions of common HVAC functions such as enthalpy, dew point temperature, PID control, and advanced mathematical functions such as logarithm, trigonometric function, and root sign.
- It has a hardware clock with a gold capacitor for continuous power backup design, which can provide normal operation of the clock after power failure.
- With network time automatic synchronization, it can accept the network time correction of central monitoring, so that the controller time in all systems is the same.
- With 200/500 BACnet analog software points (AV), digital software points (BV) and 10 digital output (BO) objects, the parameters are automatically stored in FRAM when the value/status changes, which can be used as billing or other For calculations such as energy management, a total of 10 BO points from BO0 to 9 support the priority function.

### 【Specification】

Model	Ethernet Port	FCnet Port	DFC QT'Y	Calendar	Schedule	Notification	Even Log	AV/BV Points
PF-BM12	1	2	64	2	16	2	16	200
PF-BM15	1	5	160	2	20	2	20	500

**Power Supply** : 24VAC/DC, 5VA.

**Processor** : 32 bits High Speed Micro Controller Unit (MCU) · 128K RAM · 32K FRAM 及 1024K Flash Memory

**Ethernet Port** : 10/100M Ethernet complying with BACnet Ethernet and MODBUS/TCP Sever standard protocol

**FCnet Port** : MODBUS RTU RS-485 interface with baud rate 9,600 bps, each port can connect up to 32 DFC controllers.

**Real time clock** : With backup power to keep clock normal operation within 48 hours after power down.

**Environment** : 0~50°C, 20~90%RH

**Certificate** : CE, RoHS

## [Network Architecture]

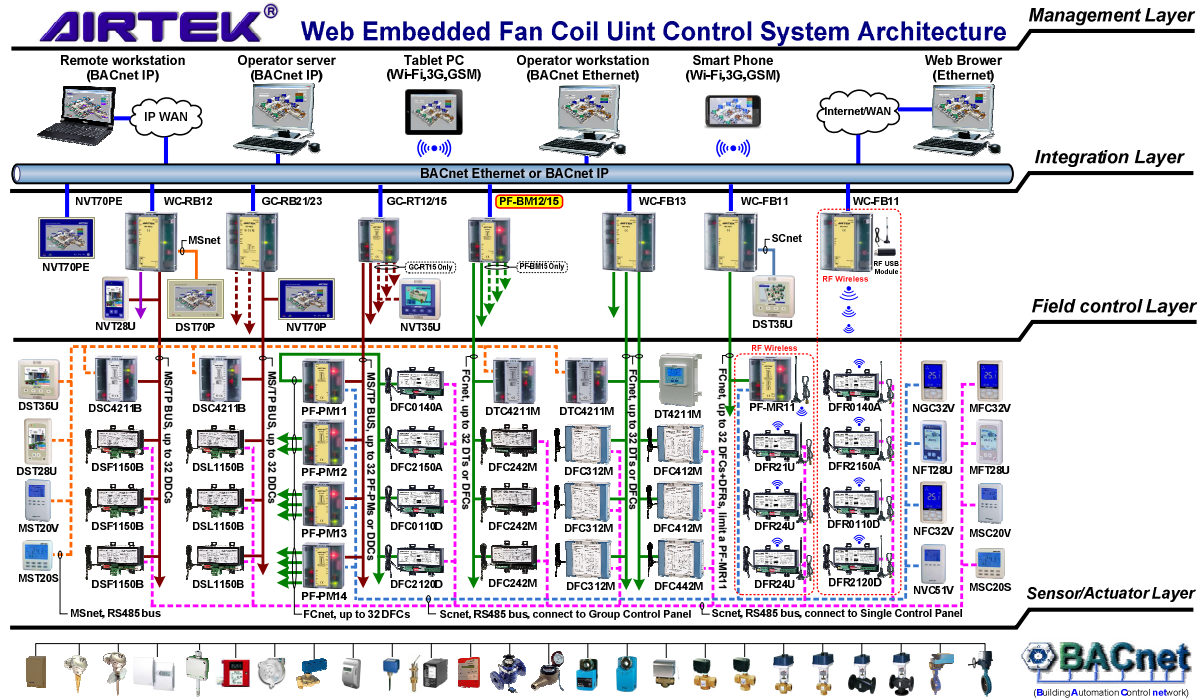

## [Wiring Diagram]

- The power supply should be one to one configuration; the action of sharing power in conjunction with other controllers or converters is prohibited.
- FCnet communication port connects to Slave devices in Master mode and only support AIRTEK DFC series not for other models or other brands.
- The 120Ω termination resistor should be installed at FCnet serial end to avoid signal attenuation.

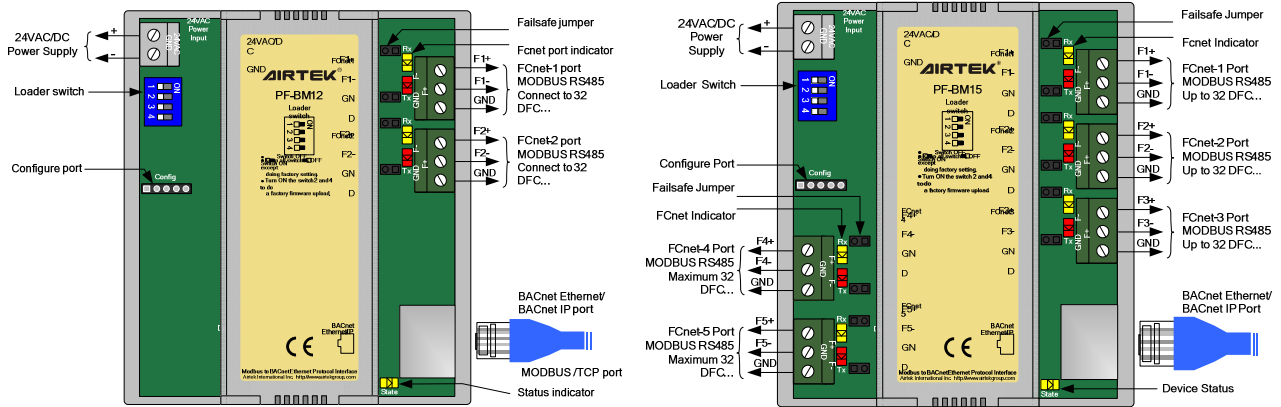

## [Dimension] Unit : mm

